



## MINIATURE COLOUR CAMERA

The AC-CESS Miniature Colour Camera is a high resolution low cost, deep rated, visual inspection tool.

- **Very small**
- **Deep rated**
- **High resolution**

A high precision quality product, depth rated to 5000m. Built around 1/3" Sony CCD video chip technology, to provide crystal clear high resolution images. Low light sensitivity, wide angle viewing and a short fixed focal length returns clear close up and distance images making it a suitable single camera solution for most applications. Features include surge and reverse polarity protection all integrated in an alloy housing with sapphire crystal window and a Hummer 5 way bulkhead connector.

- **Low light sensitivity**
- **1/3" Sony CCD sensor**
- **Surge and Reverse Polarity Protected**

Designed to combine with the AC-CESS Miniature LED Light and adjustable pan and tilt bracket.

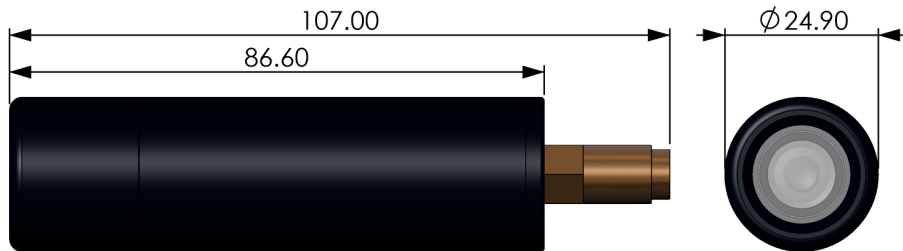

## SPECIFICATION: AC-CAM-001A

<b>RESOLUTION</b>	550 TVL
<b>LIGHT SENSITIVITY</b>	0.1 lux @ f2.0
<b>SENSOR</b>	1/3" Sony ex.view had CCD 10 bit digital processing
<b>SCANNING</b>	625 line 50Hz PAL 525 line 60Hz NTSC
<b>POWER</b>	12-24vdc
<b>CURRENT</b>	130 mA max
<b>PROTECTION</b>	Surge and Reverse Polarity
<b>VIDEO OUTPUT</b>	Composite 1.0v pk to pk
<b>LENS</b>	4.3mm auto iris

<b>FOCUS</b>	Fixed 90mm to infinity
<b>ANGLE OF VIEW</b>	60°
<b>WINDOW</b>	Sapphire Crystal
<b>DEPTH RATING</b>	5000m
<b>TEMPERATURE</b>	-10 °C to +50 °C operating
<b>DIAMETER</b>	24.9 mm
<b>LENGTH</b>	86.6 mm ex connector
<b>WEIGHT IN AIR (WITH CONN)</b>	100g
<b>WEIGHT IN SEAWATER</b>	57g
<b>CONNECTOR</b>	Hummer HUMG-5-BCR

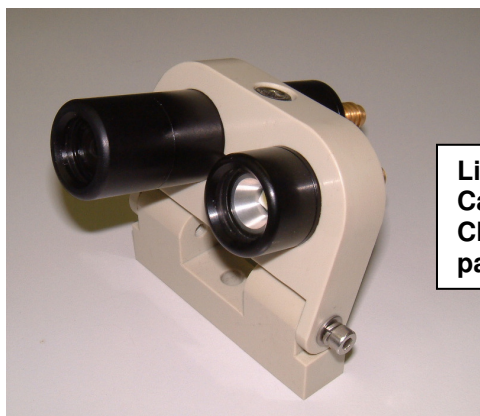

Light (AC-LED-001A) with Camera (AC-CAM-001A) Clamped in polypropylene pan and tilt bracket

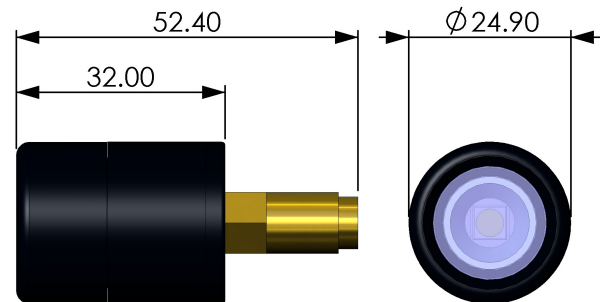

Light (AC-LED-001A)